

Turbolite

Zones: 1 and 2



Product Overview

The Turbolite is a high powered compressed air driven lamp developed from the well known Wolf Airturbo and is certified for use in Zones 1 and 2 hazardous areas, commonly used in the oil and petrochemicals industries, for tank cleaning and pipeline inspections, offering a safer alternative to low voltage lighting in dangerously wet conditions as well as where flammable gases and vapours can accumulate in confined spaces.

The Turbolite A-TL44 has a Bay Light fitting comprising a ball glass and protective polycarbonate dome to provide all-round general purpose illumination and a hook provides for suspension of the lamp in the working area or for simple fastening to a folding tripod. The Turbolite A-TL45 has a reflector head fitting for direct illumination with a polished or matt reflector giving the option of a concentrated narrow beam or diffused wide angle illumination.

The housings are cast brass, a spark free material, and the safety hook is also brass, but forged for extra strength and all external parts are nickel plated. Internal components are of durable design making the products suitable for use in the harshest industrial environments. A clean dry air supply is a condition of certification and essential for the efficient running of these lamps, otherwise contamination will deposit into the inside of the lens, reducing illumination levels. Suitable air-line filters can be supplied. Another mandatory requirement is the use of anti-static hose, to prevent the generation of unsafe levels of static electricity.

The 24 volt 250 watt tungsten halogen bulb is available in two types offering a choice of 6,000 lumens for 2,000 hours or 9,000 lumens for 200 hours. Lamps are routinely run in, tested and set to the necessary output prior to despatch and are simple and easy to maintain.

Features & Benefits

- 250 Watt Halogen Ultimate Output
- Electronic Setting Device
- Generator Overspeed Protector
- Advanced Internal Topology Rotor Design
- Spark Free Brass Casings
- International Market Leaders
- Full Accessory Range Available

Certifications



Distributed by:
Safety Lamp of Houston, Inc.
1816 Rotary Dr.
Humble, TX 77338

P: (281) 964-1019
F: (281) 964-1040
E: sales@safetylampofhouston.com
W: www.safetylampofhouston.com

Technical Specification

Product Reference		A-TL44		A-TL45	
Product Description		Safety Bay Light Compressed Air Powered		Safety Flood Light Compressed Air Powered	
Code		Ex s II T4			
Apparatus Standards		SFA 3009:1972			
Type of Protection		"s" special protection			
Area of Classification (Gas)		Zones 1 and 2, Gas Groups IIA, IIB, IIC			
Temp. Classification		T4			
Ambient Temperature		-20°C to +40°C			
Certificate		BASEEFA Ex 78209X*			
Enclosure		Nickel Plated Brass and Gun Metal			
Lens		Ball Glass/Polycarbonate Dome		Toughened Glass (15mm)	
Beam Type		All-around 360° Illumination		Flood (as standard) or Spot (to order)	
Light Source:	Part No.	A-129 (as std)	A-159 (as alt)	A-129 (as std)	A-159 (as alt)
	Type	Tungsten Halogen Filled Filament Bulb			
	Volts	24v			
	Watts	250w			
	Output	6000 lm	9000 lm	6000 lm	9000 lm
	Life	2000 hrs	200 hrs	2000 hrs	200 hrs
Power Source:	Type	Compressed Air Driven Turbo-alternator			
	Air Pressure	4.0-8.0 bar			
	Consumption	0.75m3/min			
Ingress Protection		Once pressurised may be used underwater			
Weight		7.9kg		12.2kg	
*Special certification conditions		A clean dry air supply must be used. Supply hose must be anti-static.			

- All information has been gathered under laboratory conditions, the user must regard the values given as approximate.
- Changes may be made to the above specification without notification, details are available on request.

Product Dimensions

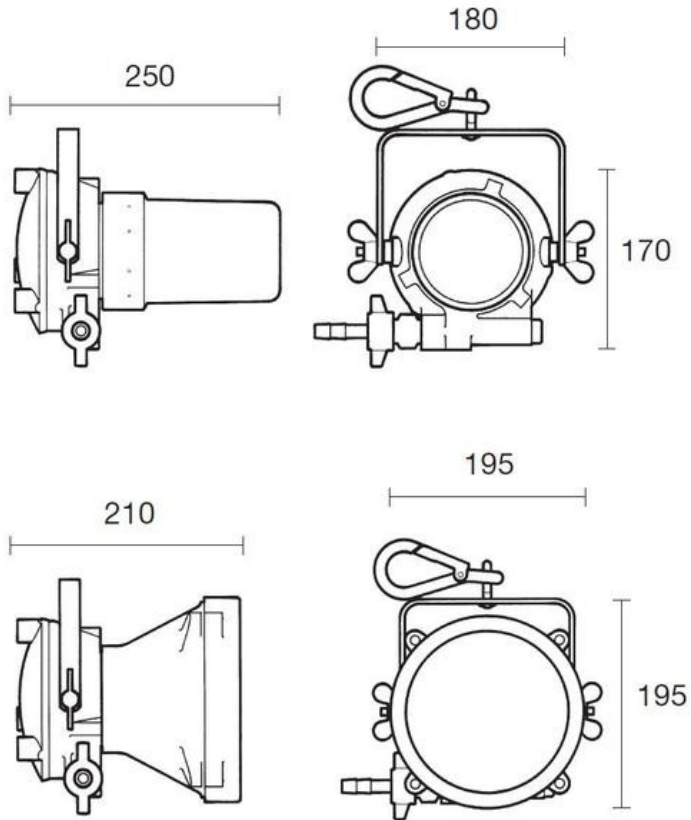

Light Output

A-TL44 - Ball Glass

Peak luminous intensity at 2.5m **70lux**

A-TL45 - Polished Reflector

Spot Beam (approx 10°)

Peak luminous intensity at 5m **2000lux**

A-TL45 - Matt Reflector

Flood Beam (approx 25°)

Peak luminous intensity at 5m **950lux**

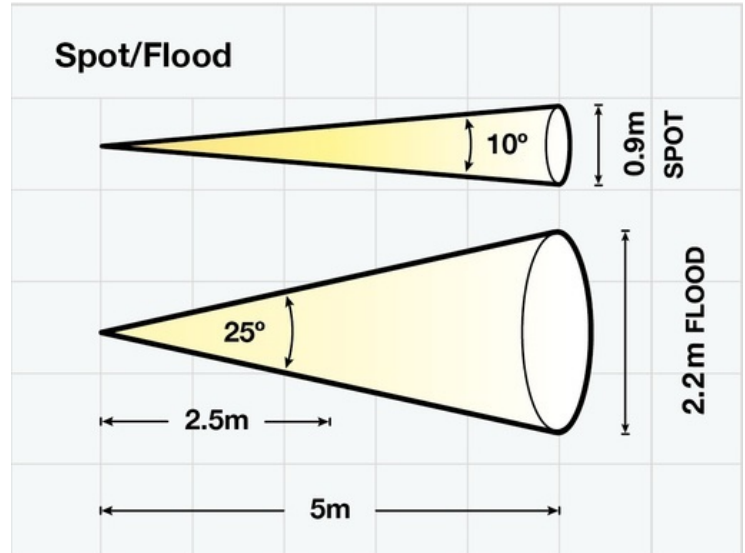

Version: SL033 Issue 2

Wolf

Wolf Safety Lamp Company, Saxon Road Works, Sheffield, S8 0YA, UK

T: +44 (0) 114 255 1051

F: +44 (0) 114 255 7988

E: info@wolf-safety.co.uk

www.wolf-safety.co.uk

ISO 9001

BUREAU VERITAS
Certification

